

SERVICE MANUAL

PARTS LIST

MODEL AP-001C

AKAI

ALSO APPLICABLE TO MODEL AP-001



TURNTABLE

MODEL AP-001C

ALSO APPLICABLE TO MODEL AP-001

SECTION 1	SERVICE MANUAL	1
SECTION 2	PARTS LIST	21

SECTION 1

SERVICE MANUAL

TABLE OF CONTENTS

I.	TECHNICAL DATA	2
II.	DISMANTLING OF UNIT	3
III.	ARRANGEMENT OF PRINCIPAL PARTS.....	4
IV.	AUTO STOP POSITION ADJUSTMENT	5
V.	CYCLE CHANGE (MOTOR PULLEY REPLACEMENT)	6
VI.	PLAYER CARE	7
	1. LIFE OF STYLUS	7
	2. STYLUS CHANGE	7
	3. LUBRICATION	7
VII.	BLOCK DIAGRAM.....	8
VIII.	TROUBLE SHOOTING CHART	14

I. TECHNICAL DATA

1. TURNTABLE SECTION

TURNTABLE	300 mm aluminium alloy die cast
DRIVE SYSTEM	Belt drive
MOTOR	4-pole synchronous motor
SPEED	33-1/3 and 45 rpm
WOW & FLUTTER	0.06% WRMS
SIGNAL TO NOISE RATIO	Better than 50 dB

2. TONE ARM SECTION

TONE ARM	Static-balanced type stainless steel tubular arm with inside force canceler and lateral balance weight
ARM LENGTH	220 mm
STYLUS PRESSURE ADJUSTMENT RANGE	0 to 4 grams
APPLICABLE CARTRIDGE WEIGHT	4 to 10 grams (10 to 15 grams using sub-weight)
ARM LIFTER	Oil damped
OVERHANG	15 mm
SHELL WEIGHT	8.0 grams

3. CARTRIDGE SECTION

CARTRIDGE	VM (dual magnet type) Audio Technica Model AT-11 with 0.7 mil spherical diamond stylus. Model AP-001C only. (Model AP-001 does not include cartridge)
FREQUENCY RESPONSE	15 Hz to 25,000 Hz
OUTPUT VOLTAGE	4 mV (1,000 Hz 50 mm/sec)
CHANNEL SEPARATION	20 dB (1,000 Hz)
OPTIMUM STYLUS PRESSURE	2.5 grams
REQUIRED LOAD IMPEDANCE	47k to 100 k ohms
WEIGHT	5.5 grams

4. GENERAL SPECIFICATIONS

POWER REQUIREMENT	CSA Models 120V, 60 Hz CEE Models 220V, 50 Hz Other Models 110V/220V, 50/60 Hz and 240V, 50 Hz
DIMENSIONS	440(W) x 140(H) x 350(D) mm (17.3" x 5.5" x 13.8")
WEIGHT	6.3 kg (13.9 lbs.)

NOTE: For improvement purposes, specifications and design are subject to change without notice.

II. DISMANTLING OF UNIT

In case of trouble, etc. necessitating disassembly, please disassemble in the order shown in photographs. Reassemble in reverse order.

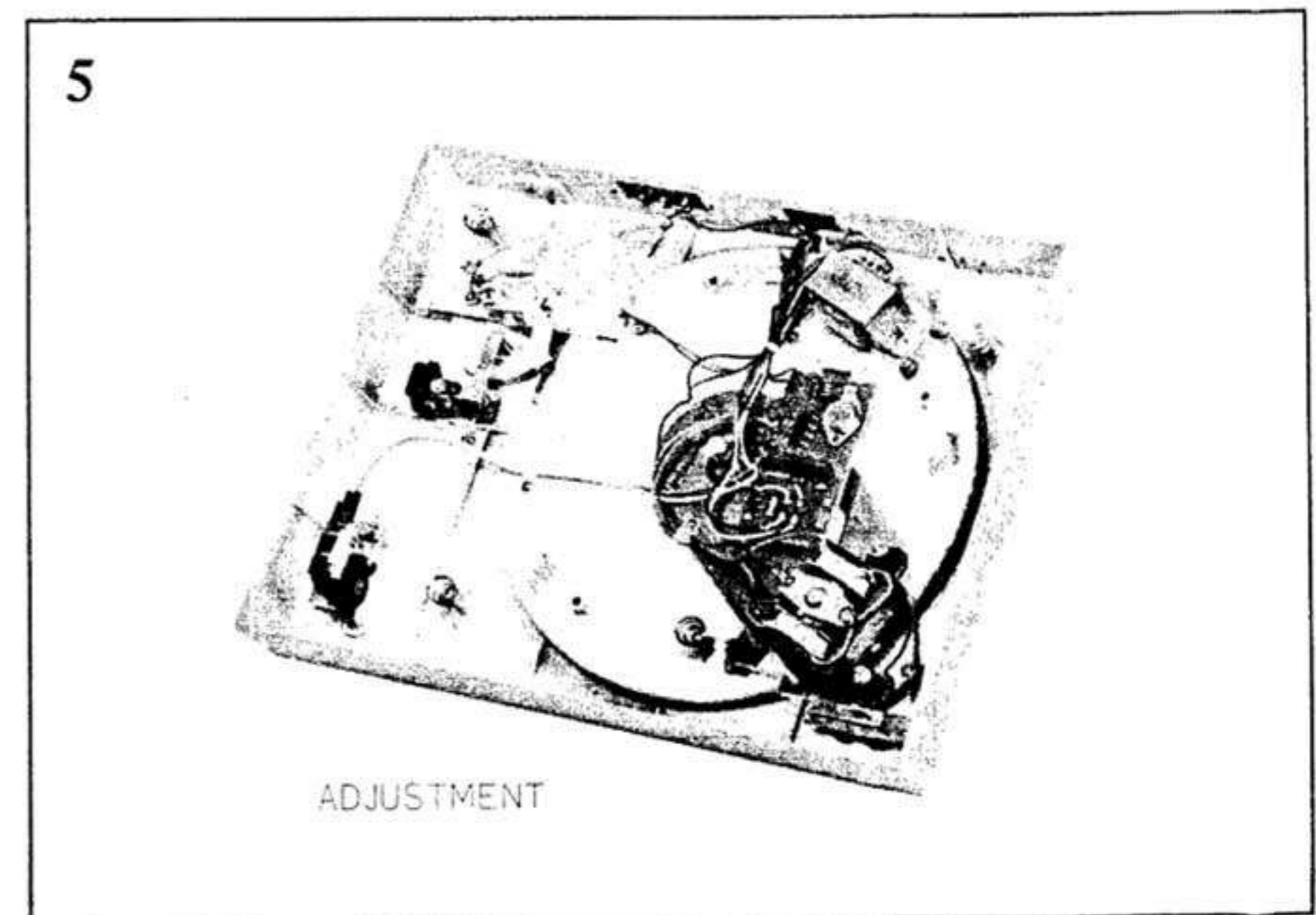
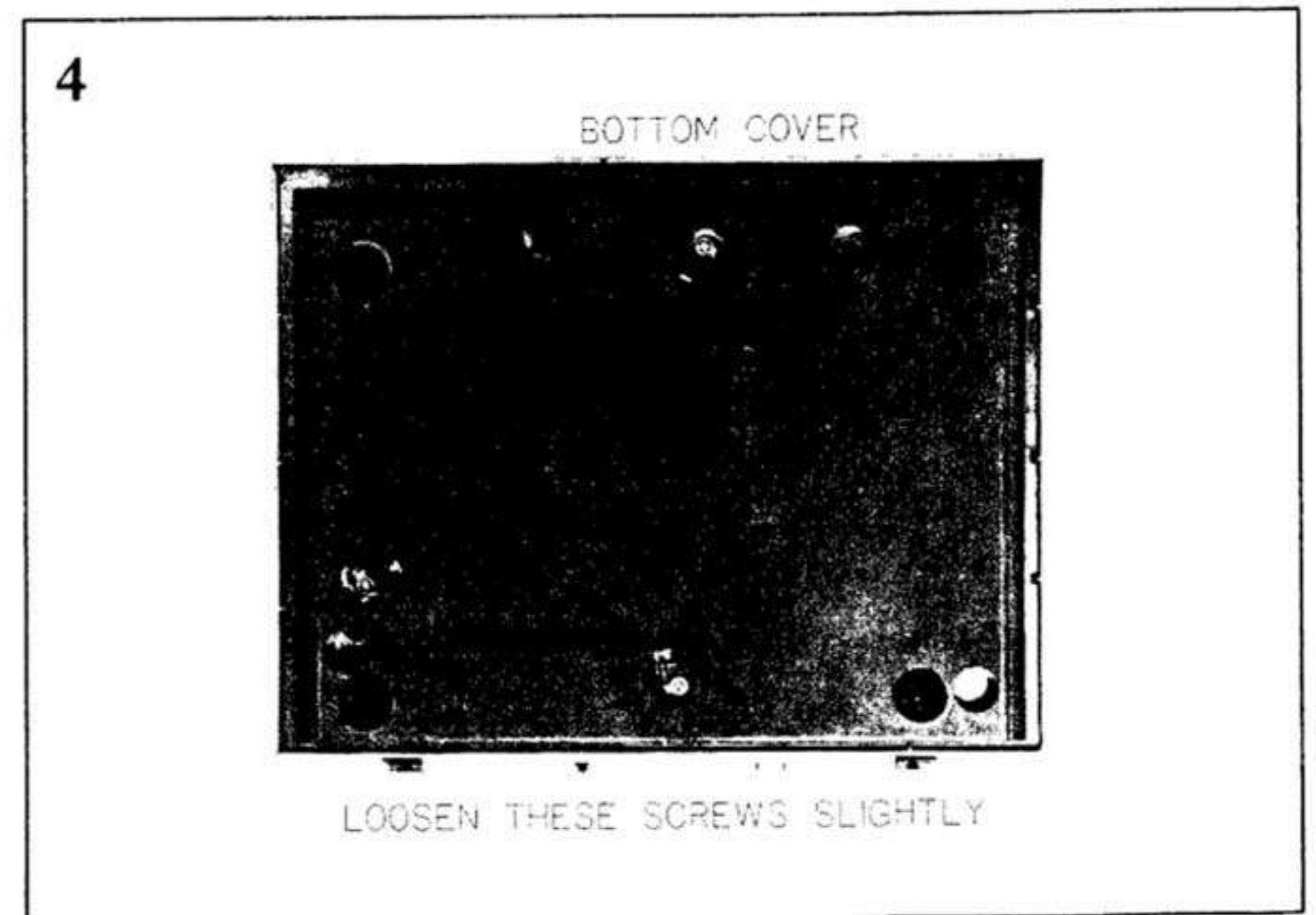
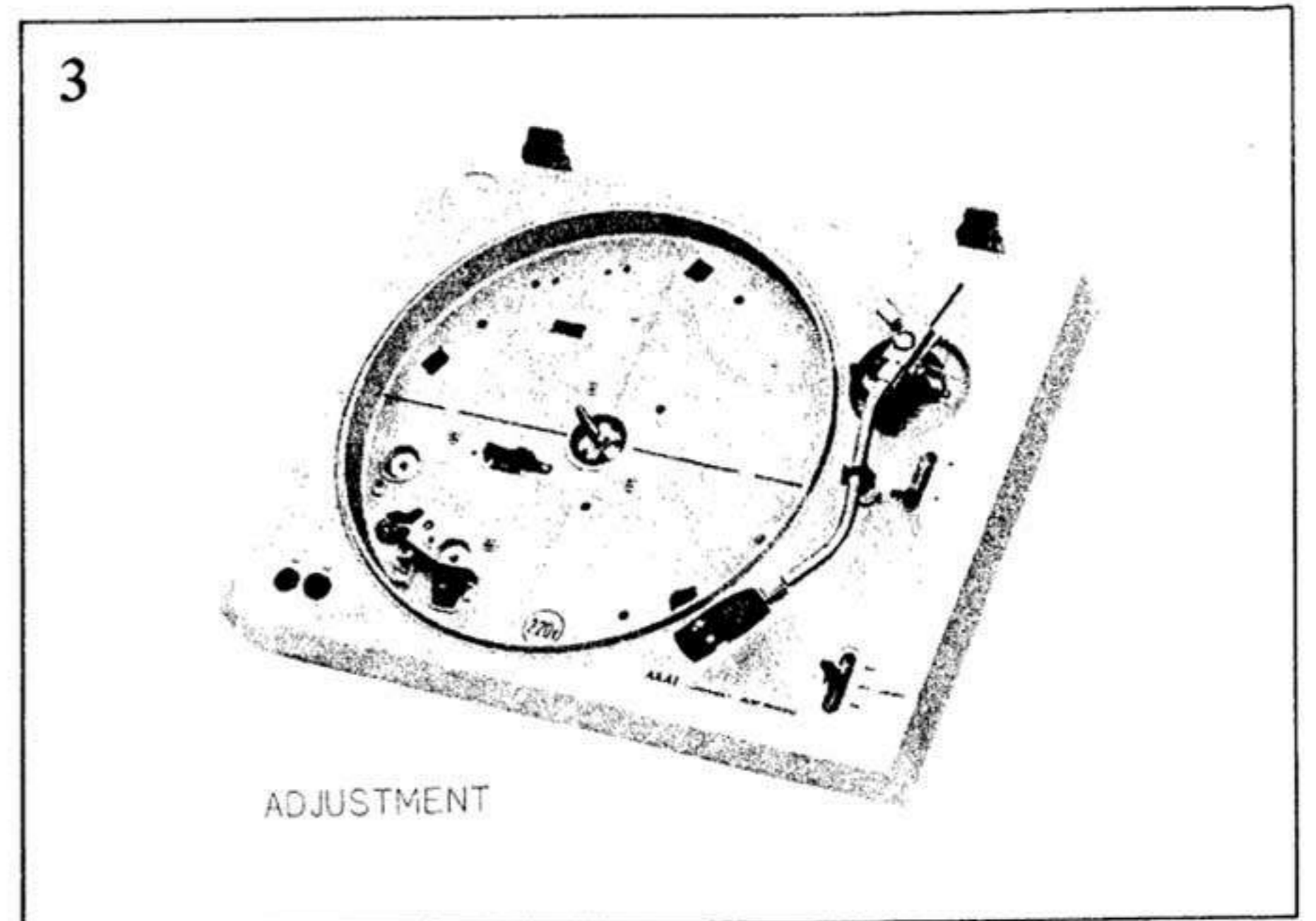
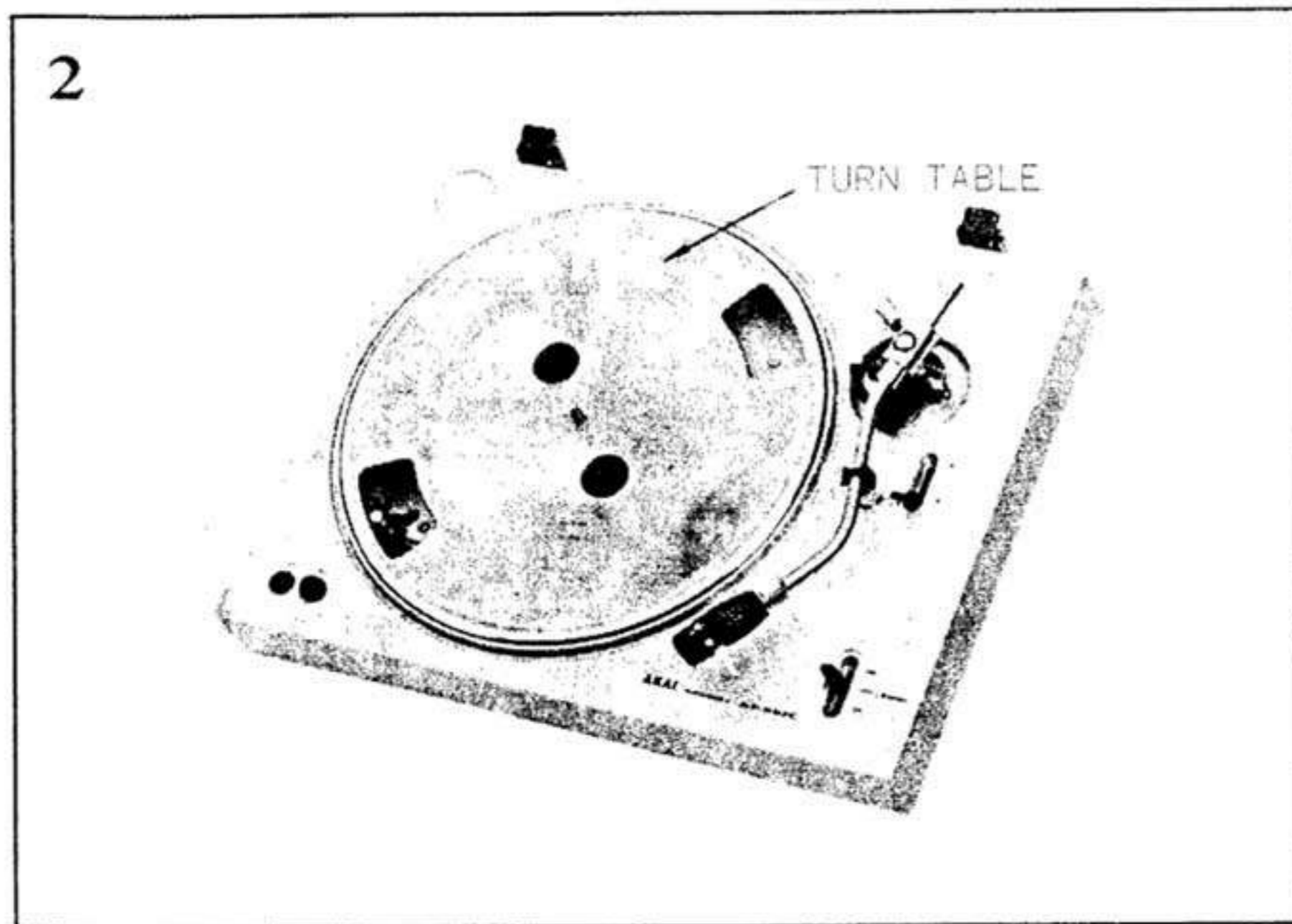

III. ARRANGEMENT OF PRINCIPAL PARTS

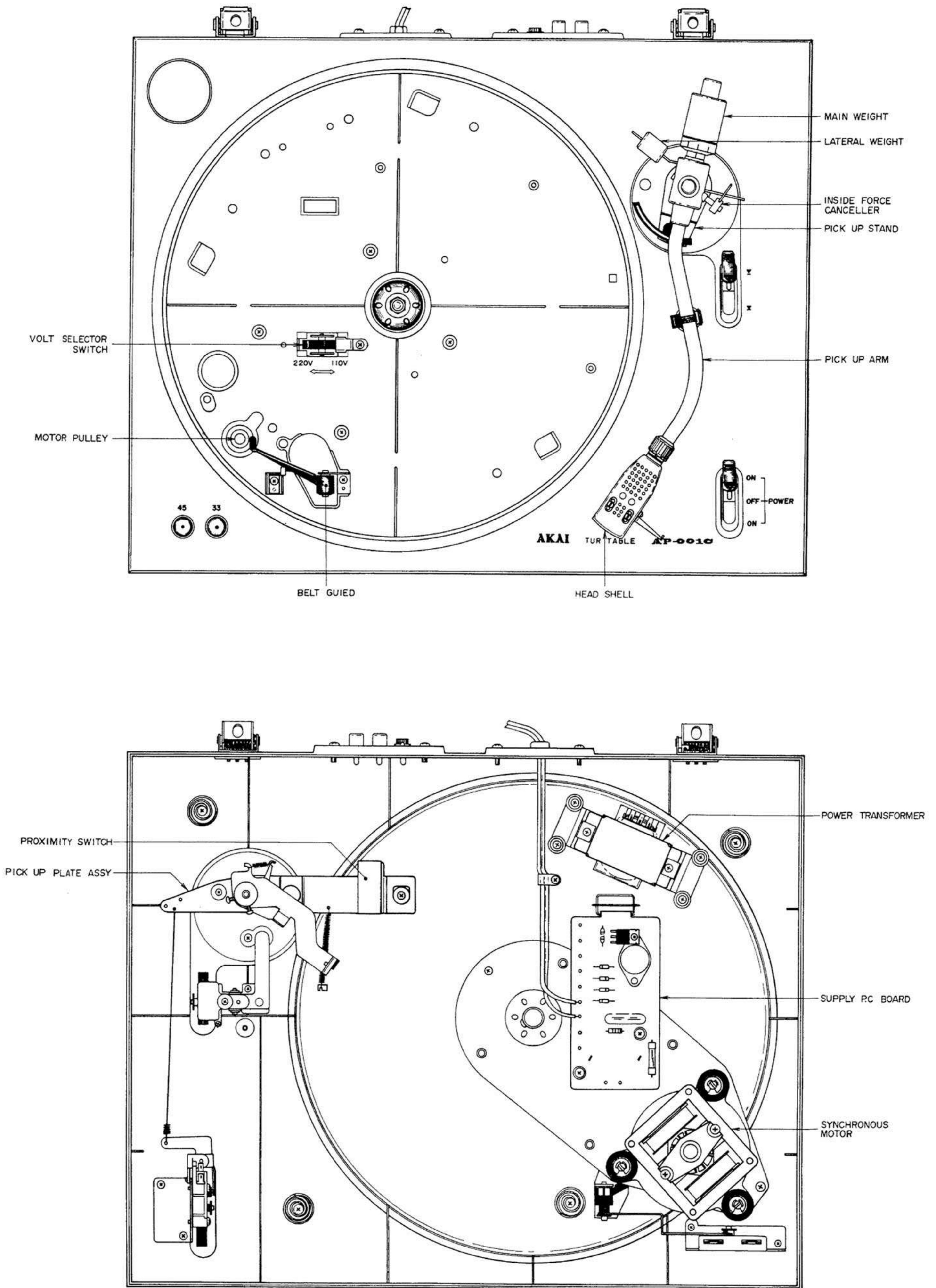

IV. AUTO STOP POSITION ADJUSTMENT

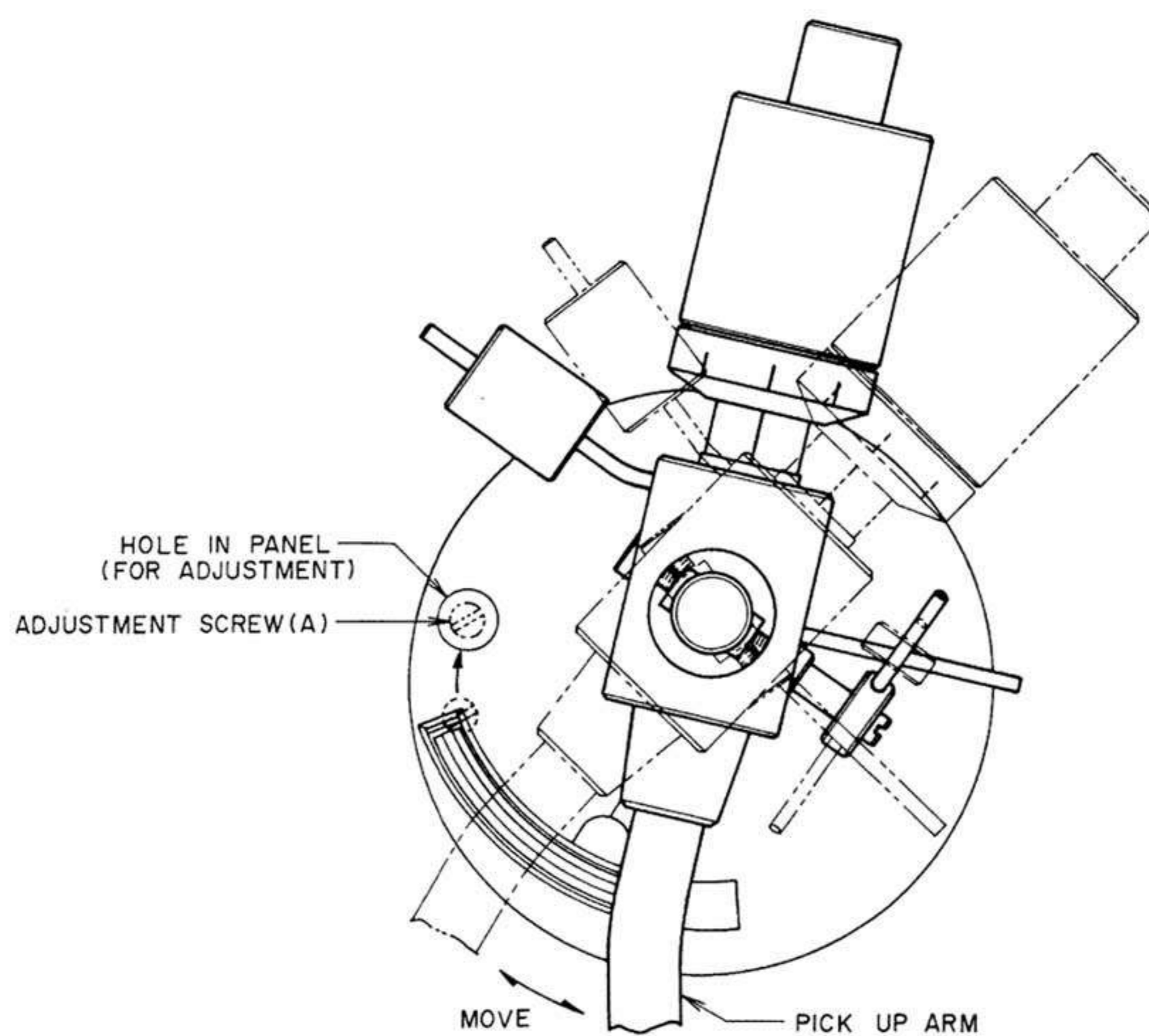

Fig. 1

Remove the rubber plug on panel toward the rear part of the pick up arm. When the pick up arm is moved as shown in Fig.1, Adjustment Screw (A) becomes accessible through the hole from which the rubber plug has been removed. When Adjustment Screw (A) is turned clockwise, stop position will be advanced and when turned counter-clockwise, stop position will be delayed.

Use a 30 cm record as standard and adjust stop position as follows with Adjustment Screw (A).

For adjusting toward outer circumference turn clockwise.

For adjusting toward inner circumference turn counter-clockwise.

If only proper inner or outer adjustment can be attained, this means that adjustment at some other place is necessary. After source of trouble has been located and corrected, re-adjust adjustment screw (A).

NOTE: 1. Because of one adjustment screw only, stop position of 30 cm 17 cm record will be the same.

2. After adjustment, be sure to re-install rubber plug.

V. CYCLE CHANGE (MOTOR PULLEY REPLACEMENT)

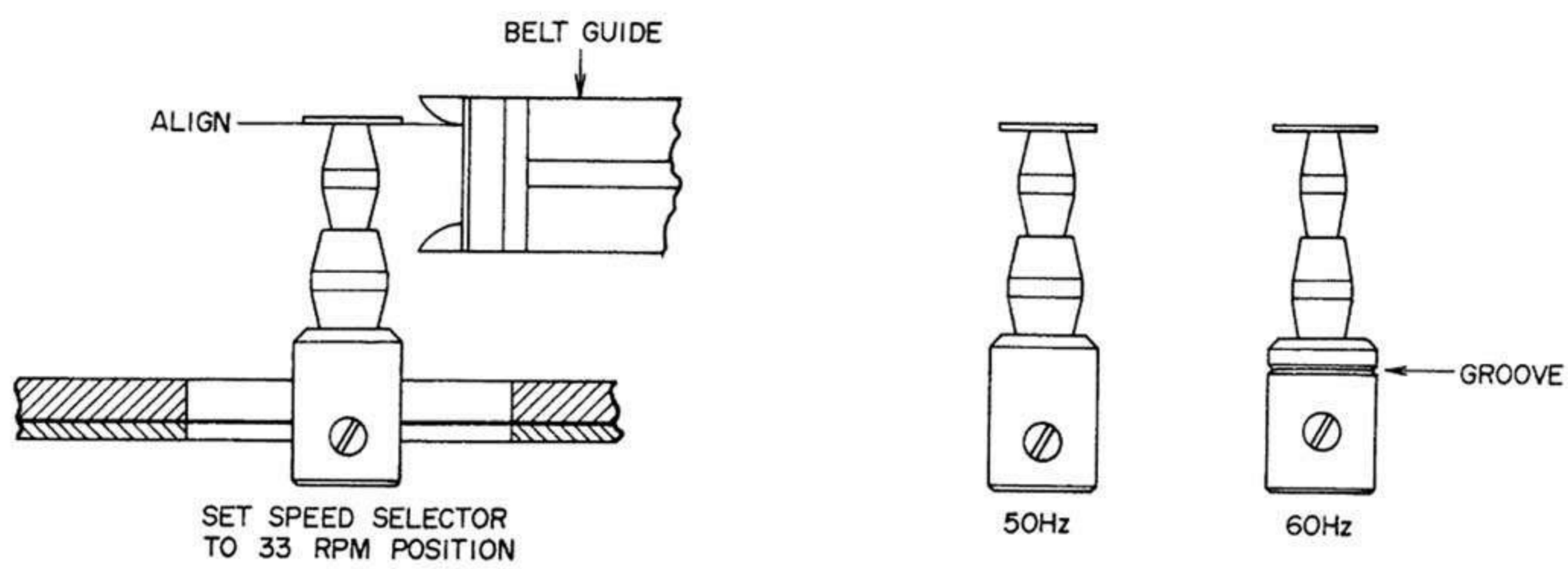

Fig. 2

50 Hz and 60 Hz cycle change is effected by changing the motor pulley.

50 Hz and 60 Hz differentiation can be determined by the groove on the 60 Hz pulley. While viewing horizontally as shown in Fig. 2, install so that the lower part of the motor pulley brim and the lower part of the belt guide are lined up. Set speed selector to 33 rpm position, install the belt and switch on power. If a rumbling noise from the belt can be heard and speed changing is not smooth, adjust installation position of motor pulley.

VI. PLAYER CARE

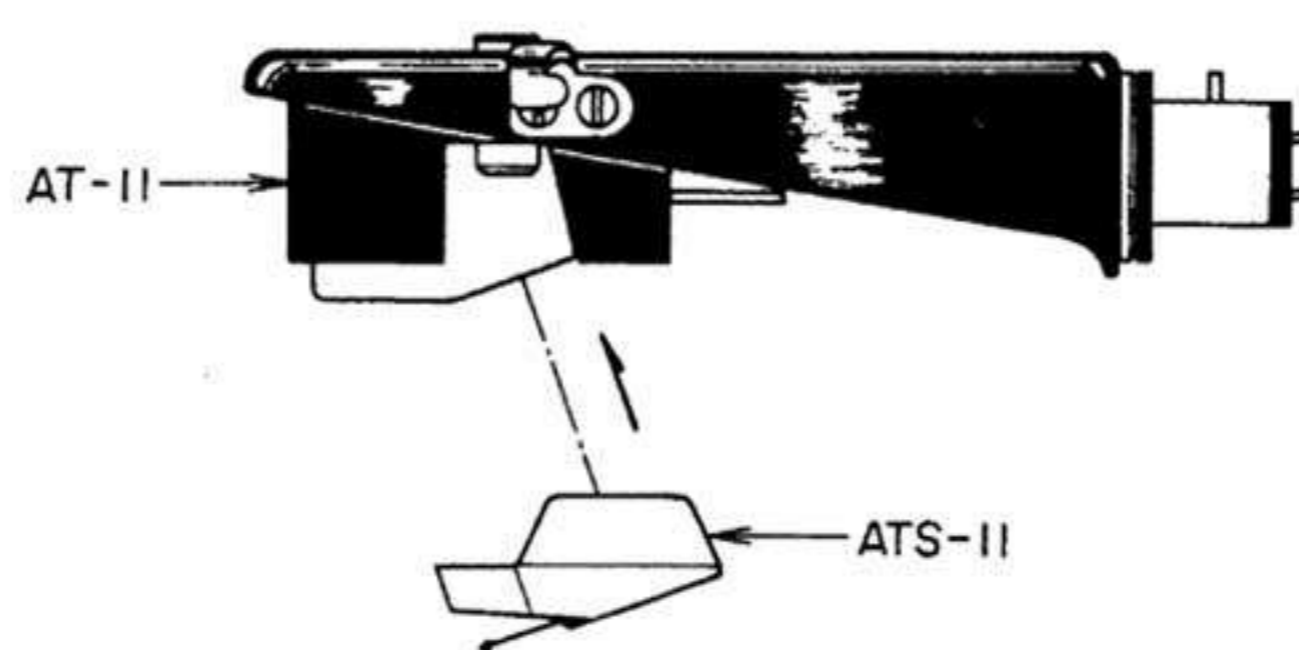

Fig. 3

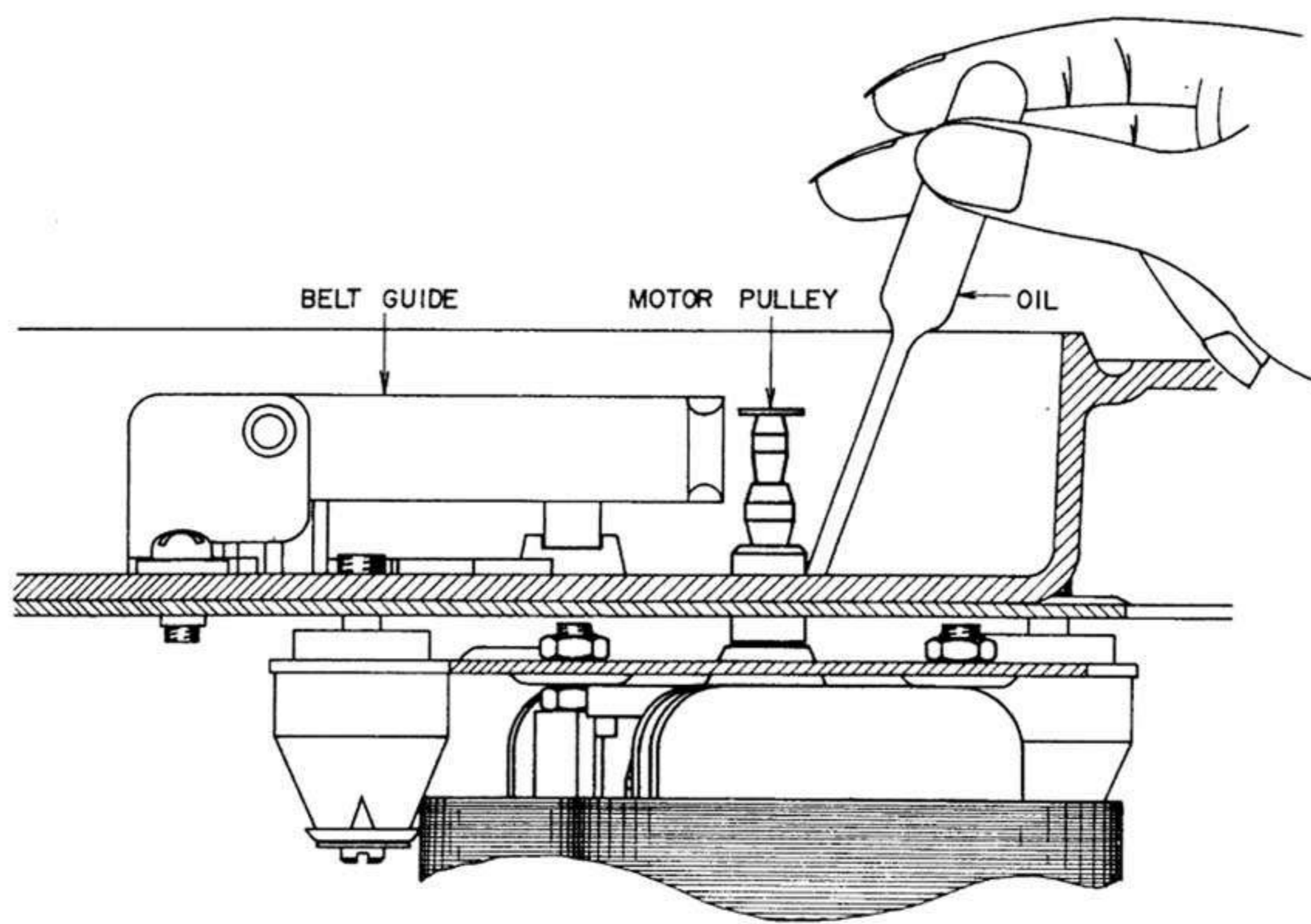

Fig. 4

1. LIFE OF STYLUS

The lifetime of stylus is about 500 hrs. of use (both sides of about 500 30 cm LP records). If the stylus becomes old, because the record will be damaged and tone quality will become inferior, be sure to replace as soon as is needed. If records on which dust is allowed to accumulate are played, the stylus will wear especially fast and the record surface will be scratched. Therefore, please be sure to keep record clean by wiping and cleaning the record grooves with water soaked gauze. Also if dust adheres to the turntable mat, as this will cause the record to become dirty easily, the mat should also be kept clean.

2. STYLUS CHANGE

When replacing stylus, be sure that the stylus (ATS-11) is inserted properly in the direction of the arrow mark shown in Fig. 3 and fits into cartridge firmly. Use only model ATS-11 stylus which is for use in model AT-11 cartridge.

3. LUBRICATION

Because for rotating parts and parts which rub together during operation, oilless metal and the best grease or oil is used, your machine will not need lubrication for some time. About once per year use standard accessory player oil, and apply one or two drops to the motor shaft as shown in Fig. 4. In case you do not have player oil, use #60 spindle oil or a high grade machine oil. If used continually for business purposes, etc., oil about once or twice per month.

CAUTION: Following lubrication, because oil will adhere to the drive belt and pulley and to the turntable etc., wipe the oil off of these parts with a cloth to which a little carbon tetrachloride or thinner (benzine can be also be used) has been applied.

VII. BLOCK DIAGRAM

1. CARTRIDGE

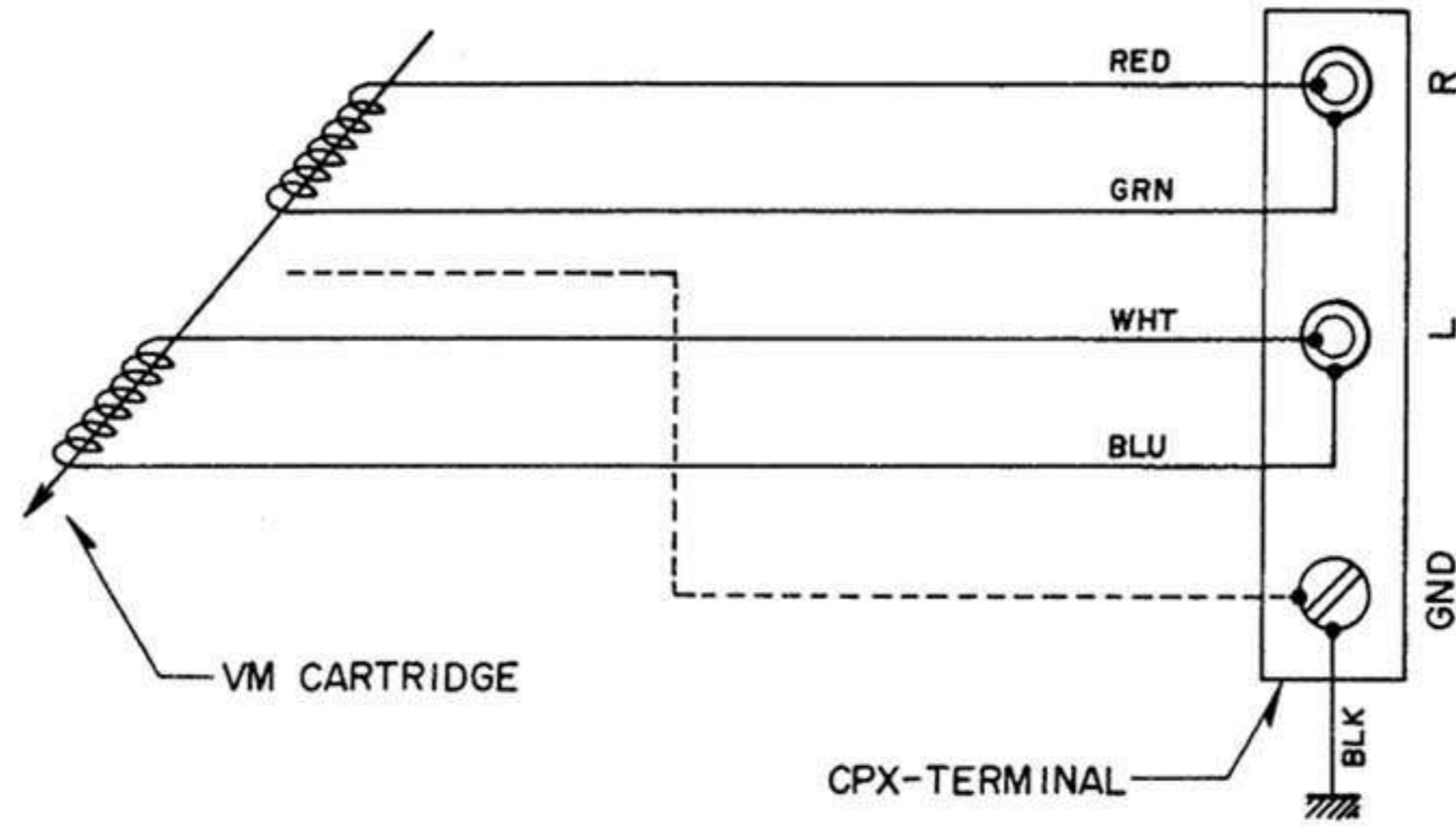

2. SWITCHABLE MODELS

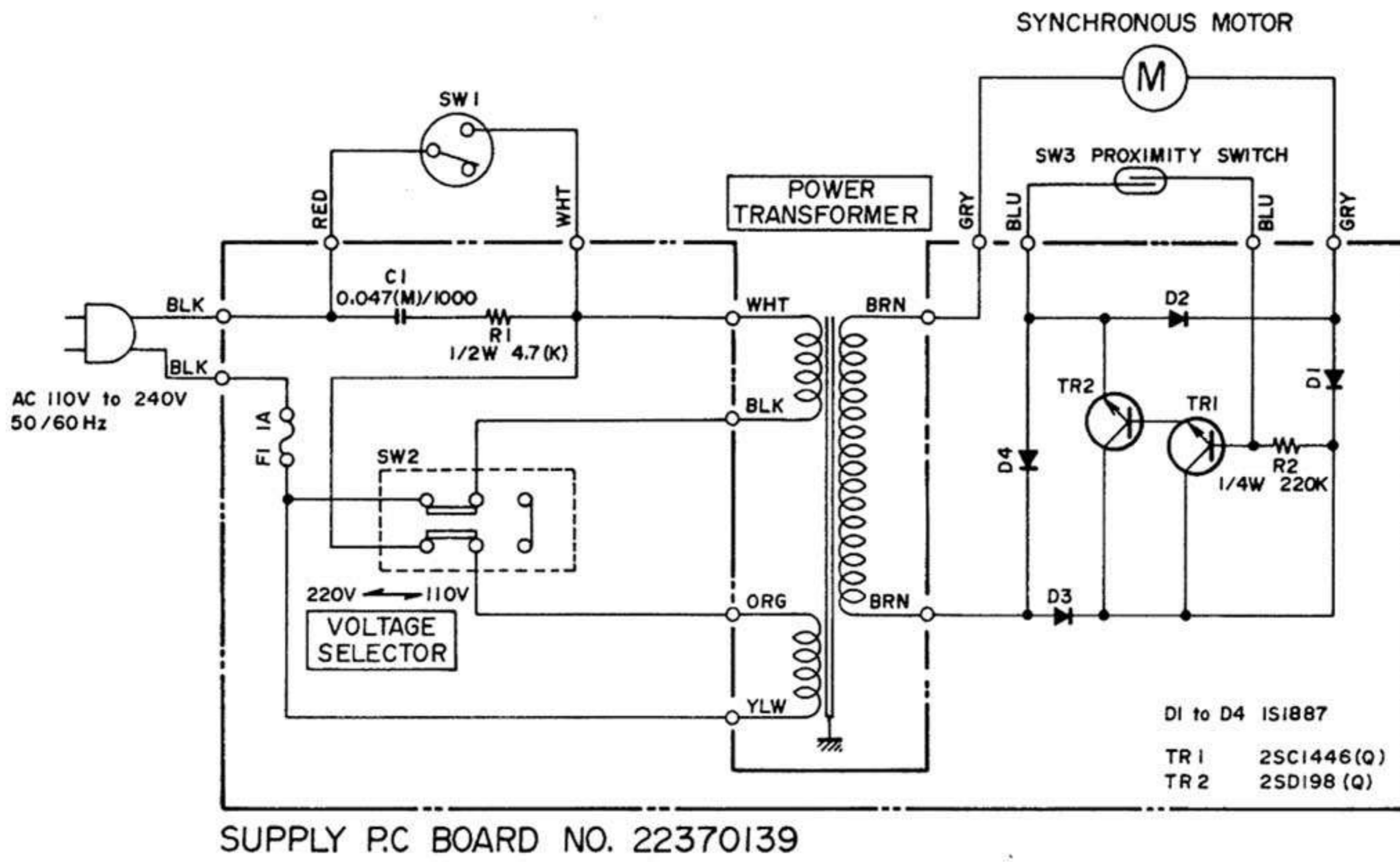

3. CSA MODELS

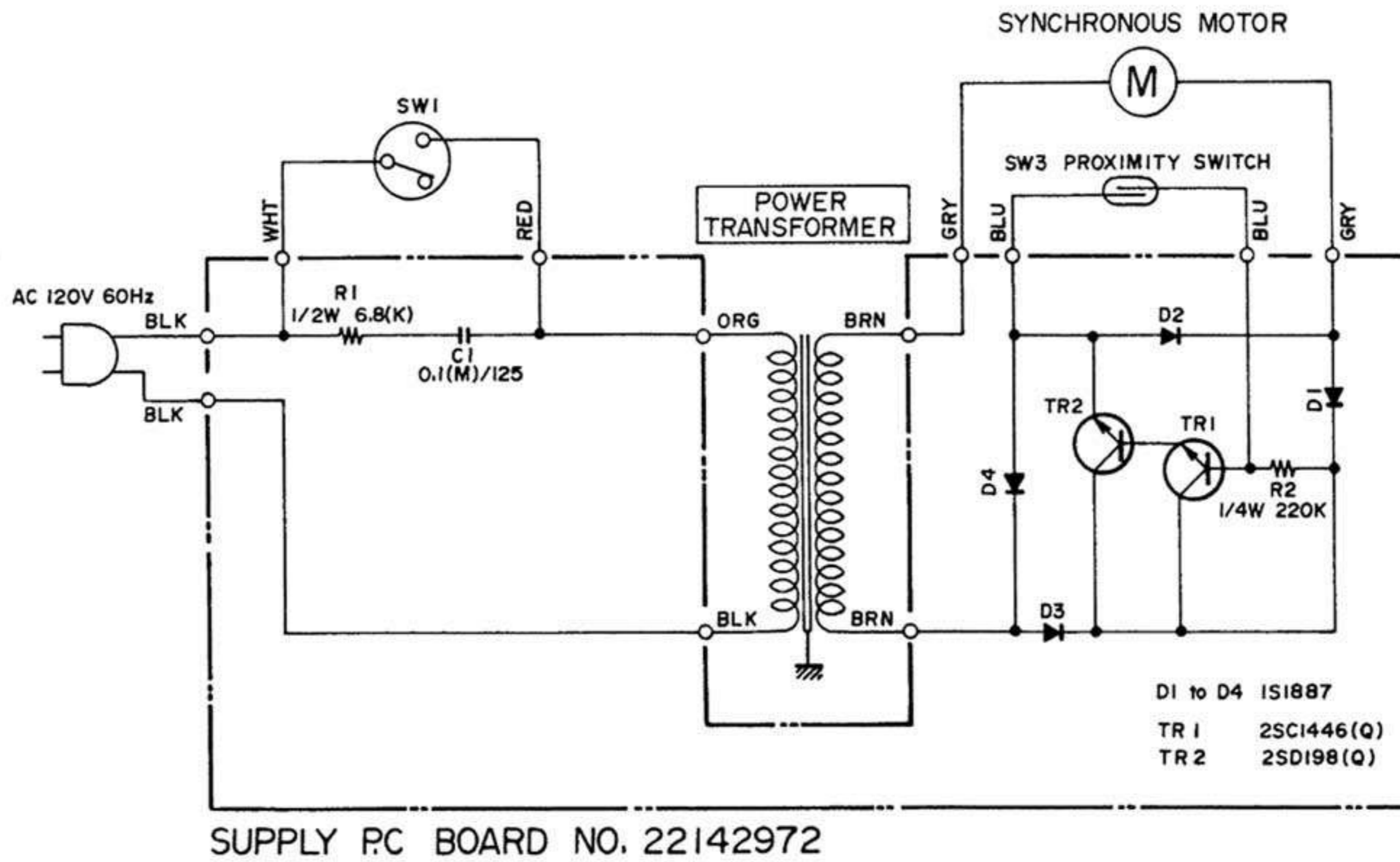

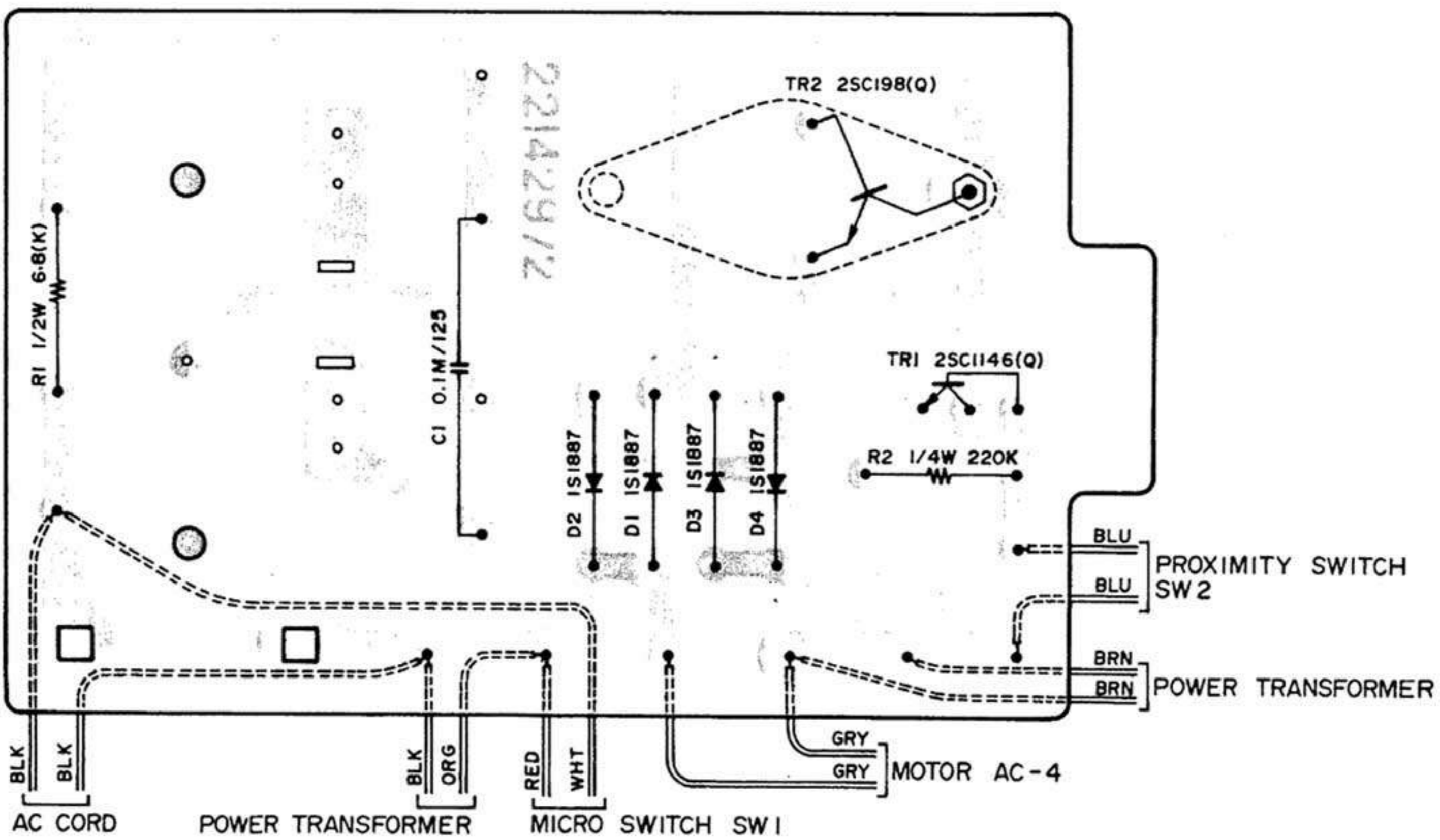
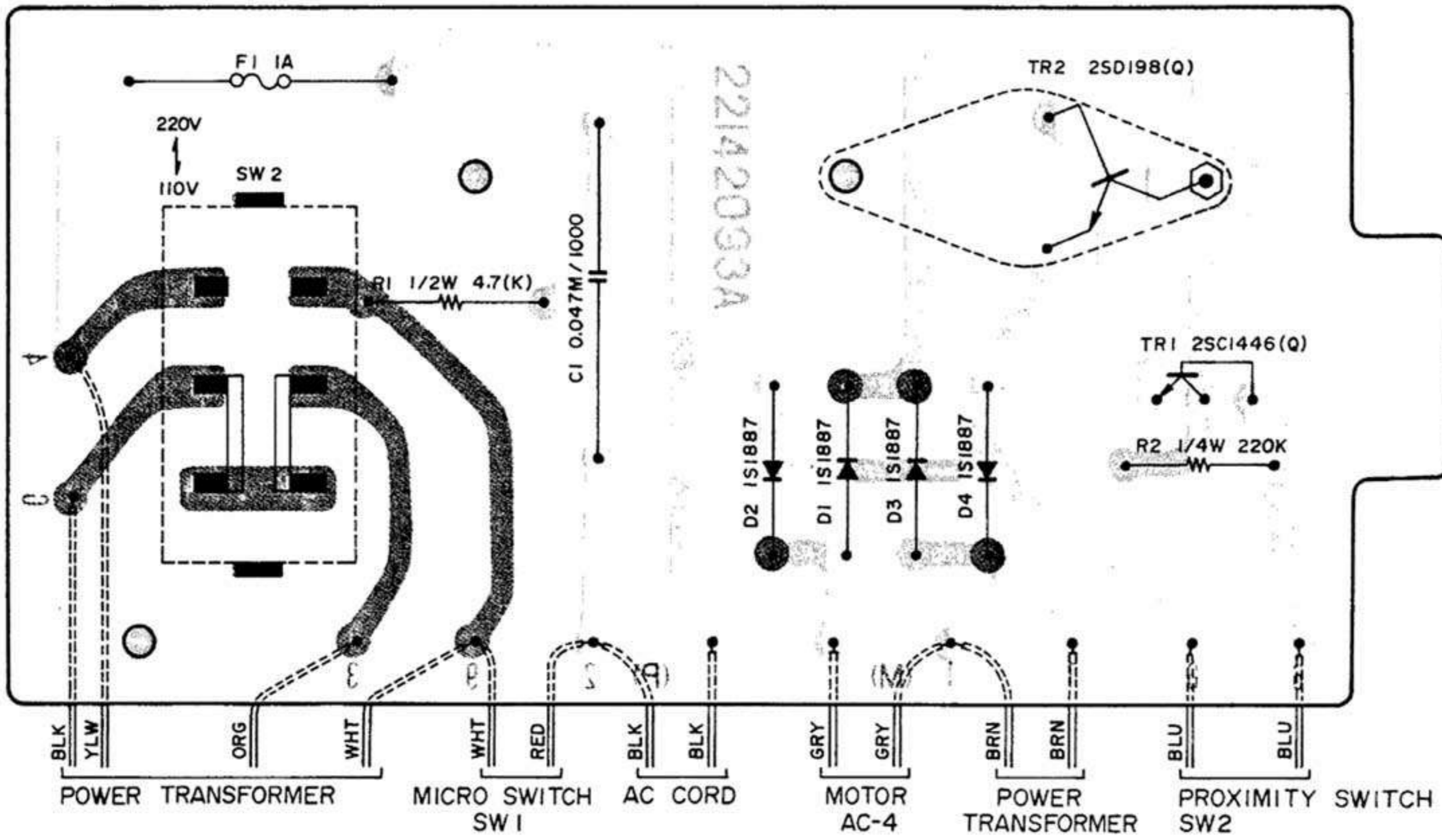

4. BSI MODELS

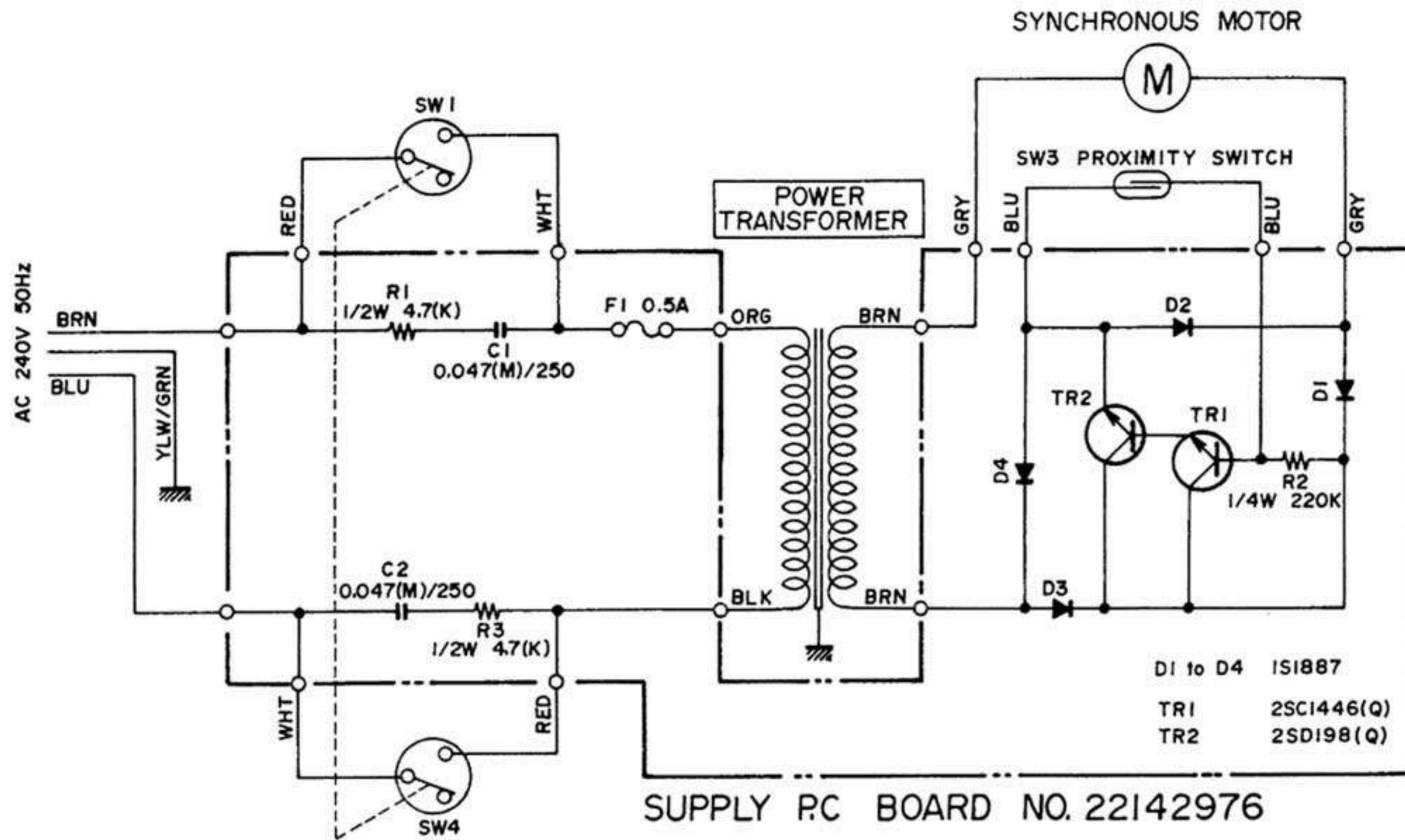

5. AST MODELS

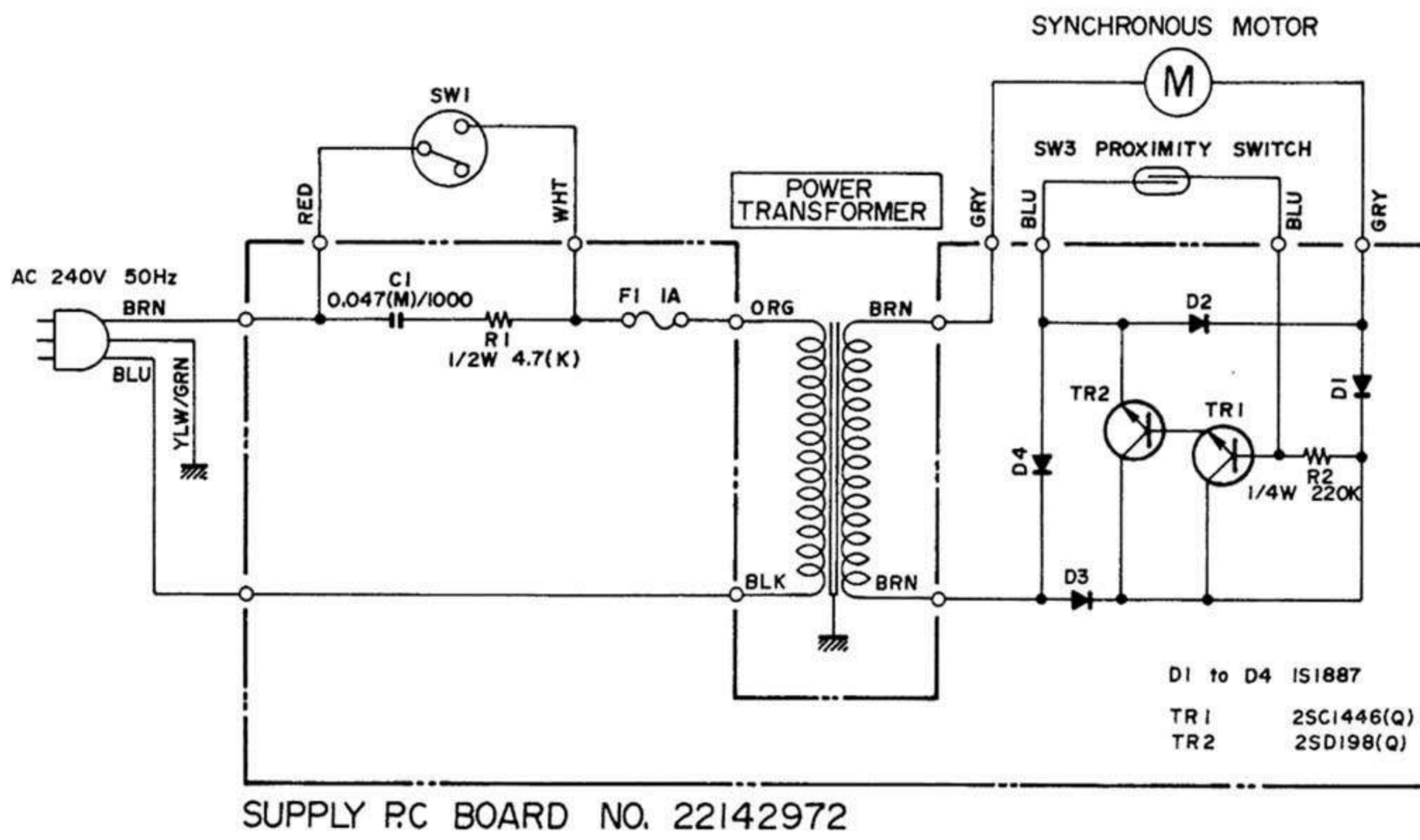

6. OTHER MODELS

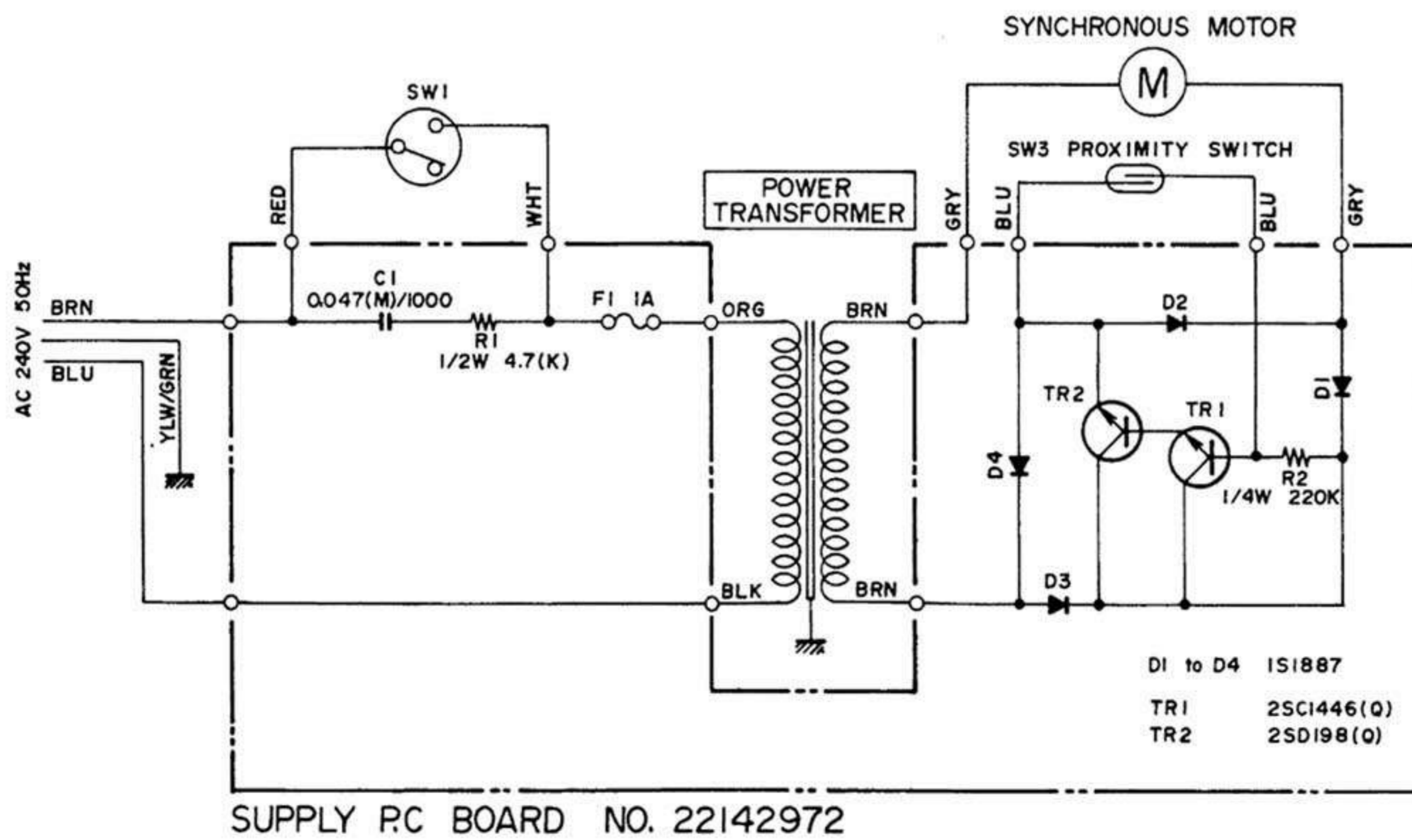

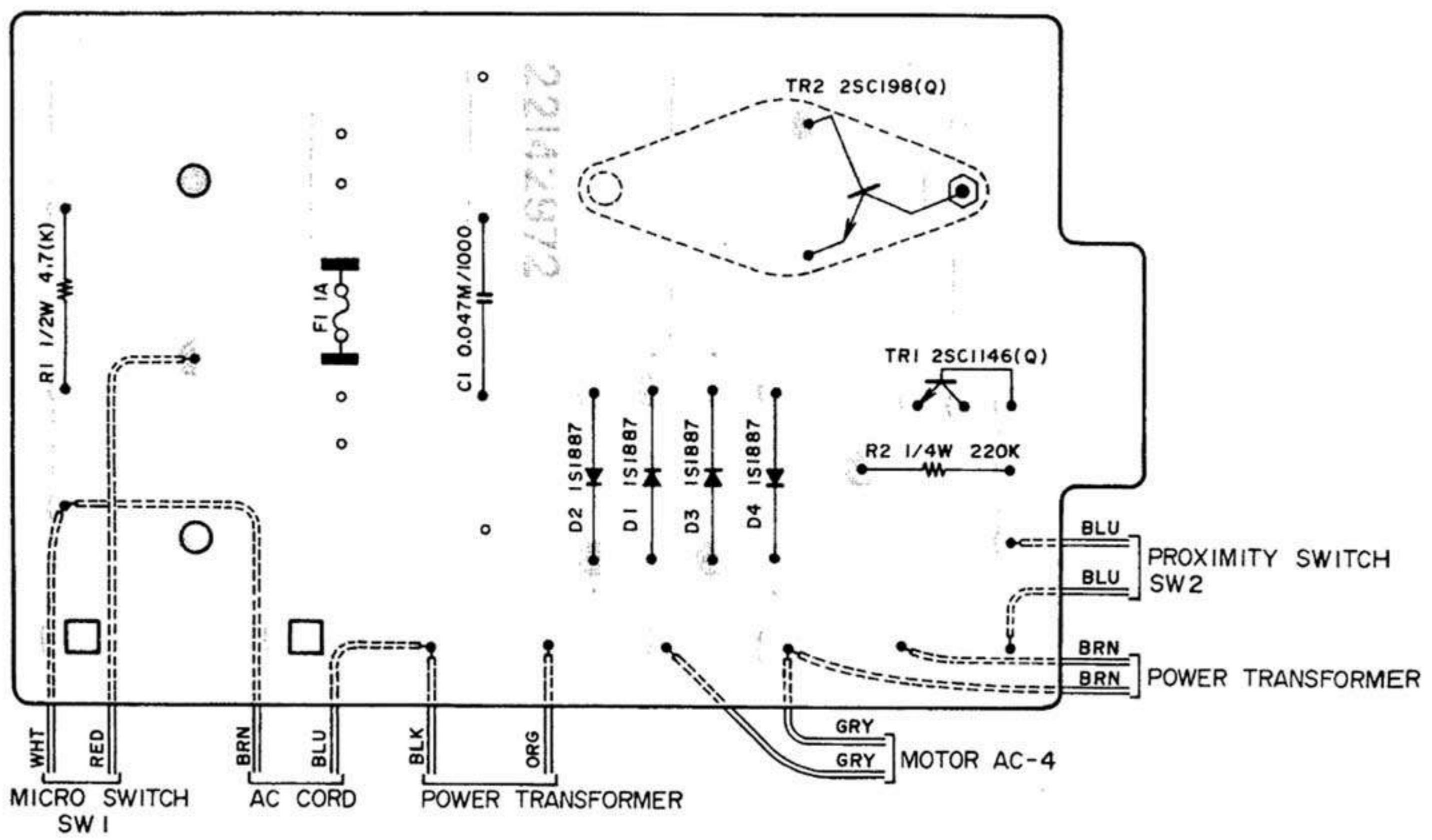
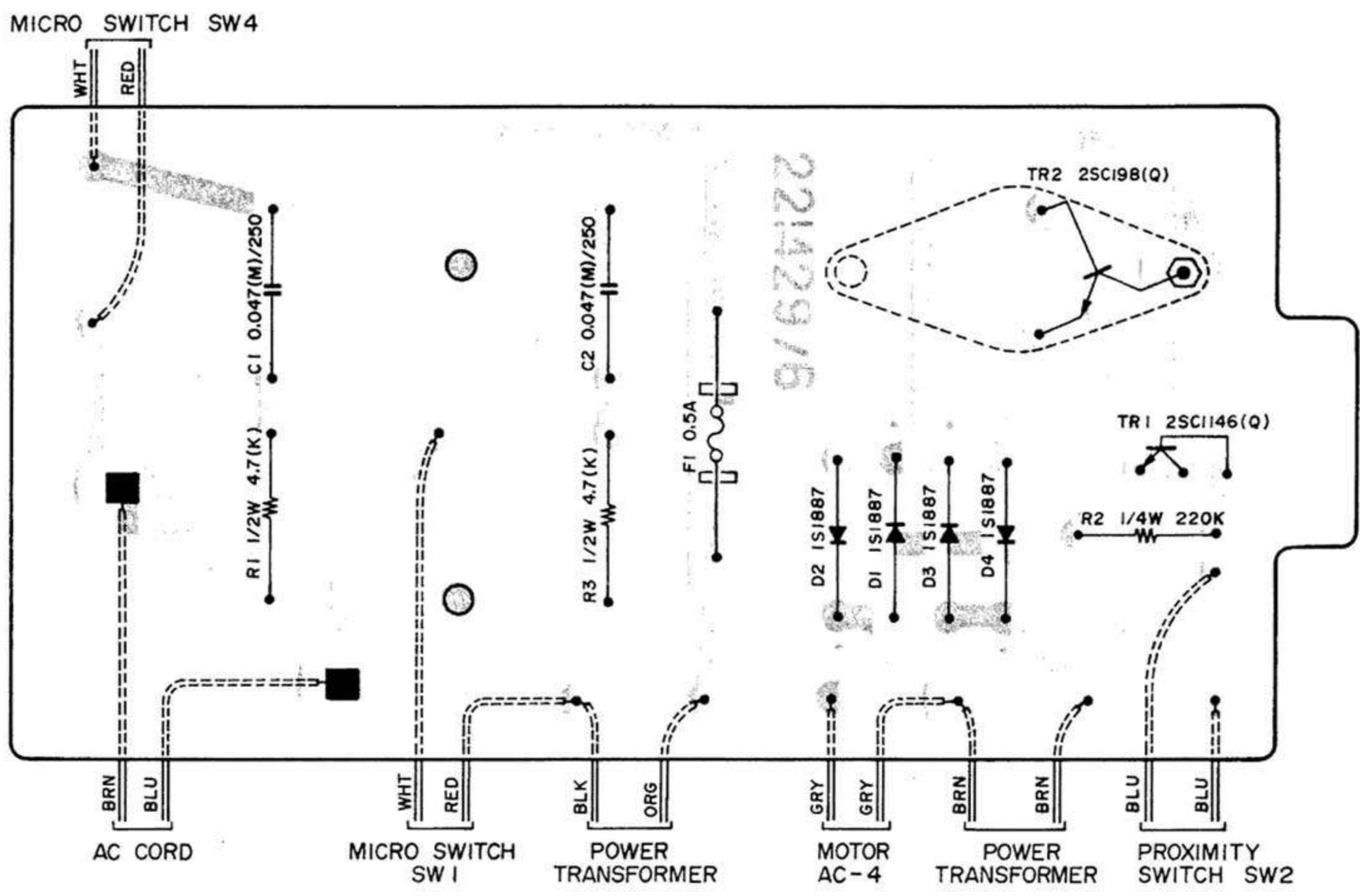

7. CEE MODELS

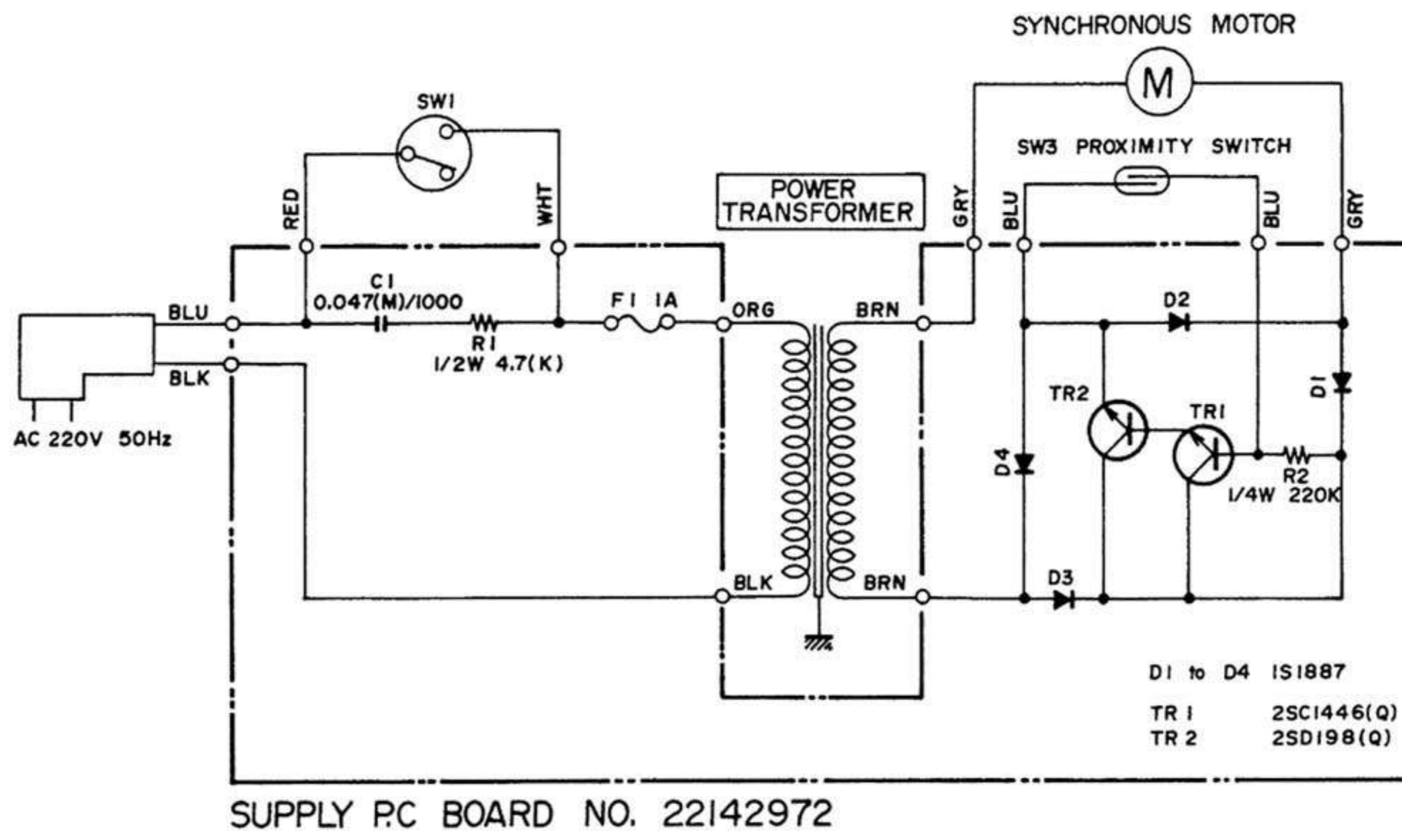

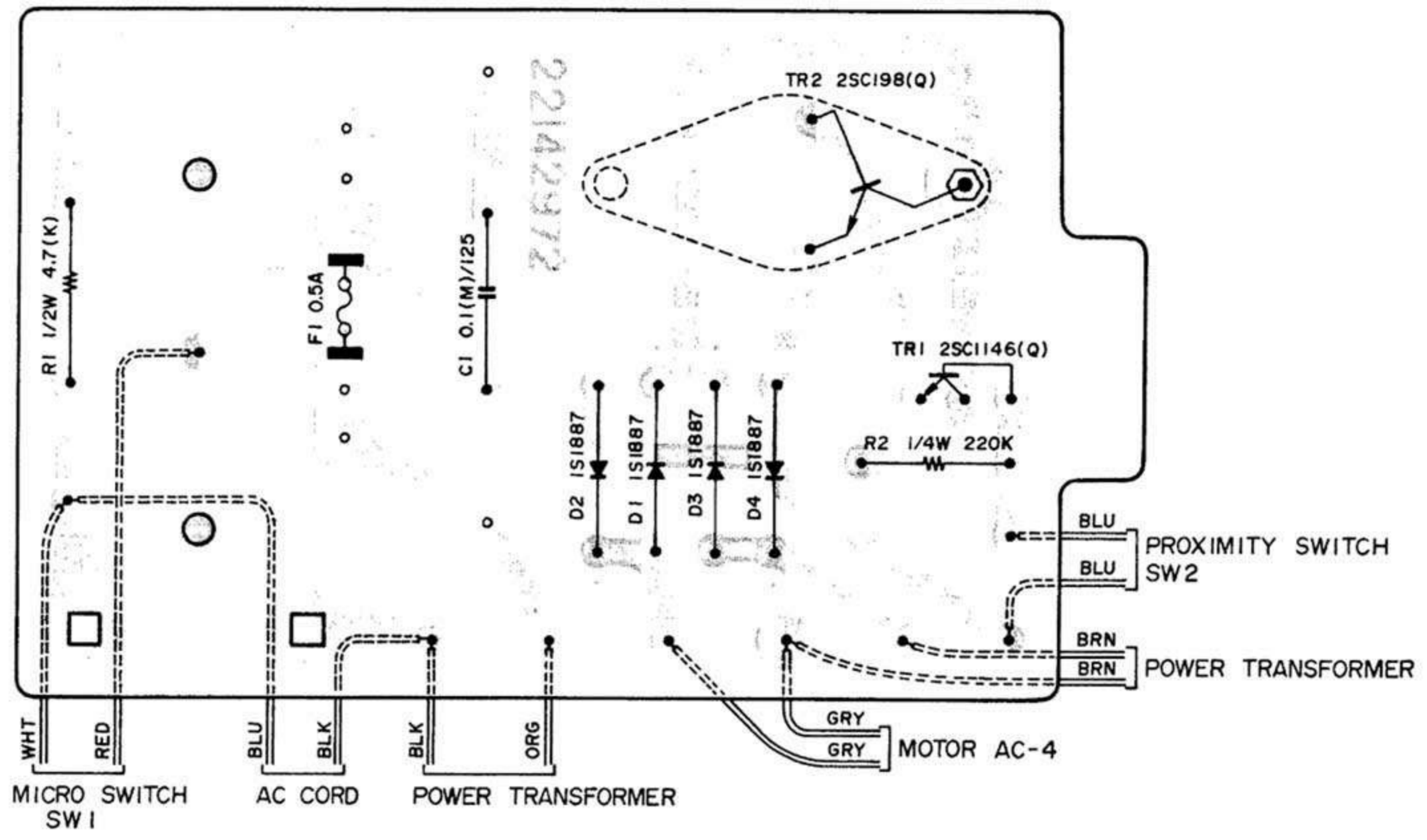

VIII. TROUBLE SHOOTING CHART

Condition	Explanation	Confirmation	Source	Countermeasure
Poor tone quality	1. Distortion (When using new record)	1. Distortion persists after changing stylus and confirming normal pick-up arm operation. (Amp. Speaker normal)	Faulty cartridge.	Replace cartridge
		2. Crackling sound even when playing new record. Especially vague at high range.	Worn stylus.	Replace stylus.
		3. A crunching sound exists and there is a sudden change in sound level. Also the level of right and left differs greatly.	Bent stylus.	
		4. Sound is vague or distortion exists.	Dust adhering to stylus.	Clean stylus.
		5. Stylus jumps.	Insufficient pressure.	Readjust stylus pressure.
		6. Stylus sinks to far into cartridge body during record playback.	Too much pressure.	
	2. Hum noise.	1. When pick up arm or player body is touched with your hand, hum noise increases.	Faulty grounding between cartridge and amp. input or turntable and amp.	Replace or repair ground wire.
		2. A hum is emitted from one channel (or both channels).	Faulty pin plug Connection.	Connect perfectly
		3. Hum is altered by changing position of lead wire from pick-up.	Lead wire from pick-up and source wiring is too close together.	Move lead wire to obtain minimum hum.
	3. Left/right sound separation poor.	Using a monaural record, left/right sound scatters and is not emitted from the center.	The plus and minus terminals are reversed on one side at cartridge out-put pin and shell pin connection or faulty cartridge.	Connect plus and minus correctly. Replace cartridge.
	4. Distortion at one channel only.	1. Observe pick-up arm head during record performance.	Bent pick-up head.	Replace pick-up arm.
		2. After pick-up arm side pressure and zero balance adjustment, pick-up arm does not move smoothly by means of inside force canceller.	Pick-up arm rotating shaft faulty.	Replace pick-up arm assy.
3. Pick-up arm heavy or catches when moved to left and right by hand.		Installation of pick-up plate assy faulty.	Correct pick-up plate installation height as specified.	
5. No sound	1. Check pin plug cord lead-through with tester.	Disconnected or broken wire.	Replace pin plug cord.	
	2. Check cartridge terminal DC resistance with tester. (L ch, R ch)	Broken or shorted wire inside cartridge.	Replace cartridge.	
Unusual noise	1. Mechanical noise (direct noise)	1. Belt contacting belt guide.	Faulty motor pulley height.	Adjust height of motor pulley.
		2. Observe motor pulley during revolutions.	Variation in motor pulley.	Replace motor pulley.
		3. During revolutions, vibration exists or noise is audible.	Faulty motor.	Replace motor.
		4. During motor rotation, if arm or table mount is touched with your hand, vibration is evident.	Faulty installation of motor or variation in motor cushions.	Adjust motor installation position. Replace motor cushion.

Condition	Explanation	Confirmation	Source	Countermeasure
	2. Electrical noise. (from speaker)	1. Sometimes shock noise and hum is emitted. Interference when lead wire is moved or no sound periodically.	Lead wire leak or lead wire is broken or disconnected. Faulty pin plug cord connection.	Repair or replace lead wire. Make proper pin plug cord connection.
		2. Interference when upper part of shell is lightly tapped.	Defective cartridge. Faulty cartridge terminal connection.	Replace cartridge. Make proper lead wire connection.
		3. Vibration and noise from motor during revolutions.	Faulty motor.	Replace motor.
Turntable does not rotate. (or rotation is unstable)	1. Electrical circuit problem.	1. Check Supply P.C Board fuse with tester.	Fuse blown.	Replace with proper fuse.
		2. Check Proximity switch lead-through with tester.	Shorted.	Replace Proximity switch.
		3. Check power switch lead-through with tester.	Open.	Replace micro switch.
		4. Check main lead wires with tester.	Disconnected or broken lead wire.	Replace or repair lead wire.
		5. Check motor coils with tester.	Disconnected or broken wire.	Replace motor.
		6. When rotor is rotated by hand, it catches or rotation is not light and smooth.	Insufficient oil.	Lubricate rotor shaft and clean.
	2. Table shaft out of order.	When turntable is rotated by hand it seems heavy. Unusual noise and too much rattle (with belt removed).	Insufficient oil.	Lubricate table shaft and bearing. Replace table shaft.
	3. Speed change mechanism defective.	1. Slippage between belt, motor pulley and turntable.	Worn out belt. Oil adhering to belt.	Replace belt. Clean with carbon tetrachloride or alcohol.
		2. Belt does not run on middle of motor pulley (drum-like part).	Faulty motor pulley height.	Adjust motor pulley height and motor slant.
		3. Belt rubbing noise.		
4. Revolutions too slow. (or uneven)	Check for variation in shape of belt and whether dust is adhering to belt, motor pulley and turntable.	Variation of belt. Dust.	Replace belt. Clean with carbon tetrachloride or alcohol.	
Operation of manual lifter faulty. (at record performance)	1. Lifting or lowering takes place too fast when manipulating the lifter manually.	1. Observe plate spring.	Variation in shape or bent.	Repair or replace.
		2. Check lifter shaft silicon oil.	Insufficient silicon oil.	Apply silicon oil (200000CS).
	2. Lifting or lowering is too slow when manipulating the lifter manually.	1. Check strength of pressure coil spring.	Pressure coil spring has lost strength.	Replace pressure coil spring.
		2. Check lifter silicon oil.	Too much oil.	Wipe off oil.
Position of arm auto stop faulty.	1. Too soon.	Auto stop takes place too soon (17 cm, 30 cm record).	Faulty adjustment.	Use a 30 cm record as standard and adjust by turning adjustment screw (A) counter-clockwise.
	2. Too late.	Auto stop takes place too late (17 cm, 30 cm record).	Faulty adjustment	Use a 30 cm record as standard and adjust by turning adjustment screw (A) clockwise.

Condition	Explanation	Confirmation	Source	Countermeasure
	3. Auto stop of either 17 cm or 30 cm record sooner or later than normal auto stop.	When the bottom panel is removed and the movement of the aluminum plate (switch holder plate) on which the Proximity Switch is installed is changed by manipulating the change lever, the stopper screw sticks to part of the square hole in the aluminum plate and does not move freely.	Faulty connection pole or adjustment.	Replace connection pole and also change holes (choose the most suitable of the 3 holes) at tip of aluminum plate to which connection pole is connected.
	4. Specified stop position.	30 cm, 25 record operation begins between 115φ and 109φ (center 56R). 17 cm record operation begins between 106φ and 98φ (center 51R).		

1. ILLUSTRATION OF ASSEMBLY BLOCK (1)

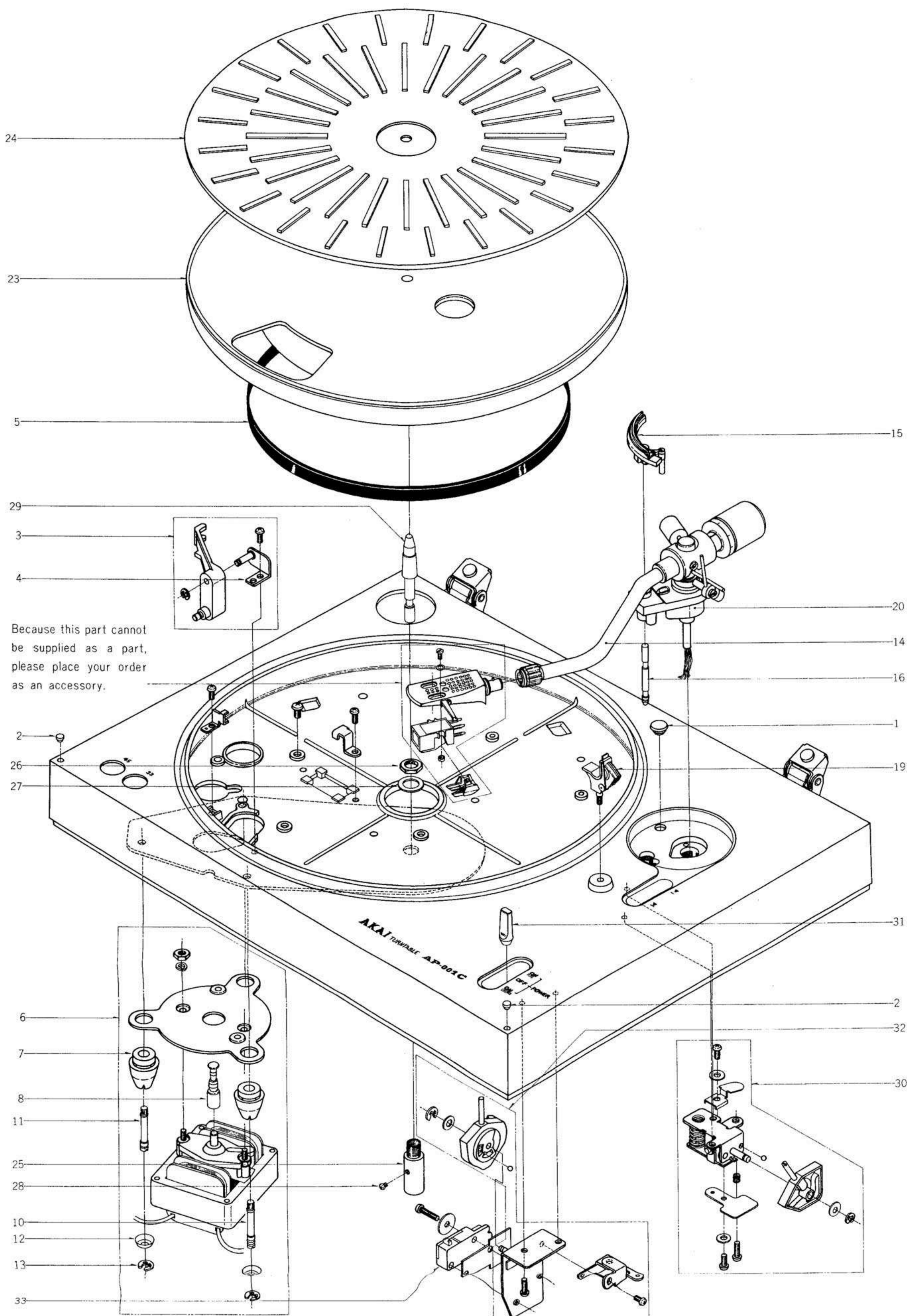

Because this part cannot be supplied as a part, please place your order as an accessory.

AKAI Turntable AP-001C

Off Power

2. ILLUSTRATION OF ASSEMBLY BLOCK (2)

